

AR3/C

**CUTTING RING
WITH TIGHT SEALING
FOR PIPE FITTINGS
DIN 2353 (ISO 8434-1)**

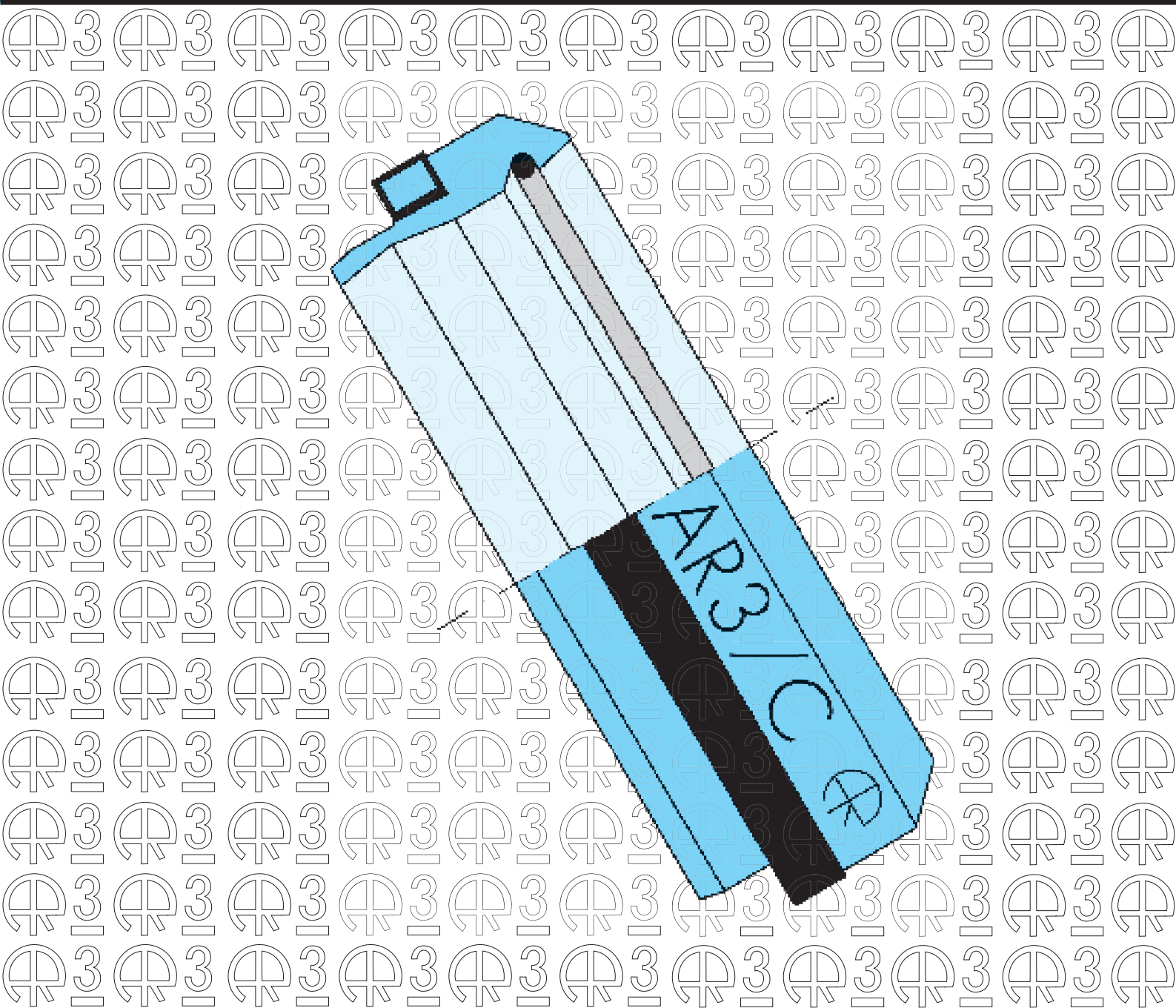

**RASTELLI
RACCORDI - s.r.l.**
27019 VILLANTERIO (PV)-ITALIA

Tel. 0382 963000 r.a. - 967257 - 967067 - Fax 0382 967080 - 963210
web: www.rastelliraccordi.com - e-mail: marketing.it@rastelliraccordi.com

- TORINO
Corso Traiano, 70/72
Tel. 011-611508 / 6197041
Telefax 011-6191106
- PADOVA
Via Navigazione Interna, 9
Tel. 049-7800933
Telefax 049-7800234
- BOLOGNA
Calderara di Reno
Loc. Bargellino
Via dell'Industria, 4e
Tel. 051-728889 / 728886
Telefax 051-727486
- AVELLINO
S.Martino Valle Caudina
Strada Statale 7 - km.246
Tel. 0824-832720
Telefax 0824-832720

- D-73760
OSTFILDERN-NELLINGEN
Felix Wankel Str.25
Tel. (0711)3412086
Telefax (0711)3412142
- 28000 CHARTRES-FRANCE
1, Pôle Atlantis
Téléphone: 02-37.30.24.66
Télécopie: 02-37.90.79.82
- 44335 NANTES-CEDEX 3
61, Rue de la Garde - BP93509
Téléphone: 0033 2 40521905
Télécopie: 0033 2 40521961
- 08107 MARTORELLES
Barcelona (ESPAÑA)
C/Can Fanosa n. 18
Polígono Industrial Roca
Teléfono 93-5705895
Telefax 93-5705954

OUR ADDRESSES

HEAD OFFICE

Rastelli Raccordi - s.r.l.

27019 VILLANTERIO (PV) -ITALIA
Tel. (+39) 0382/963000 r.a. - 967257 - 967067
Fax. (+39) 0382/967080 - 963210
email: marketing.it@rastelliraccordi.com
administration.it@rastelliraccordi.com
sito internet: www.rastelliraccordi.it
www.rastelliraccordi.com

Branch Offices in Italy

TORINO

Corso Traiano, 70/72
Tel. 011/611508 - 6197041 - Fax 011/6191106
email: torino.it@rastelliraccordi.com

PADOVA

Via Navigazione Interna, 9
Tel. 049/7800933 - Fax 049/7800234
email: padova.it@rastelliraccordi.com

AVELLINO

S.Martino Valle Caudina

Strada Statale 7 - Km. 246
Tel. 0824/832714 - Fax 0824/832720
email: avellino.it@rastelliraccordi.com

BOLOGNA

Calderara di Reno - Loc. Bargellino

Via dell'Industria, 4/e
Tel. 051/728889 - 728886 - Fax 051/727486
email: bologna.it@rastelliraccordi.com

Branch Offices in Europe

D-73760 OSTFILDERN-NELLINGEN

Felix Wankel Str.25
Tel. 0711/3412086 - Fax 0711/3412142
email: germany@rastelliraccordi.com

28000 CHARTRES-FRANCE

1, Pôle Atlantis
Téléphone: 02/37302466
Télécopie: 02/37907982
email: france1@rastelliraccordi.com
email: france2@rastelliraccordi.com

44335 NANTES-CEDEX 3

61, Rue de la Garde - BP93509
Téléphone: 0033 2 40521905
Télécopie: 0033 2 40521961
email: nantes@rastelliraccordi.com

08107 MARTORELLES - Barcelona (ESPAÑA)

C/Can Fanosa n. 18
Poligono Industrial Roca
Teléfono 93/5705895 - Telefax 93/5705954
email: espana@rastelliraccordi.com

QUALITY CERTIFICATES



RINA
www.rina.org

- CERTIFICATE N° 95/94/S



- CERTIFICATE N° IT 2633

PRODUCT APPROVALS



- CERTIFICATE N° DG4502BS0493

- CERTIFICATE N° DG4502BS0494

1. CLAMPING RING AR3/C

1.1 PRESENTATION

The new clamping ring AR3/C (Figure 1), has been designed and developed by RASTELLI RACCORDI with the aim of offering to the market a specific, simplified product that is now available together with ring AR3, the version manufactured in stainless steel only, of which it keeps the following basic characteristics:

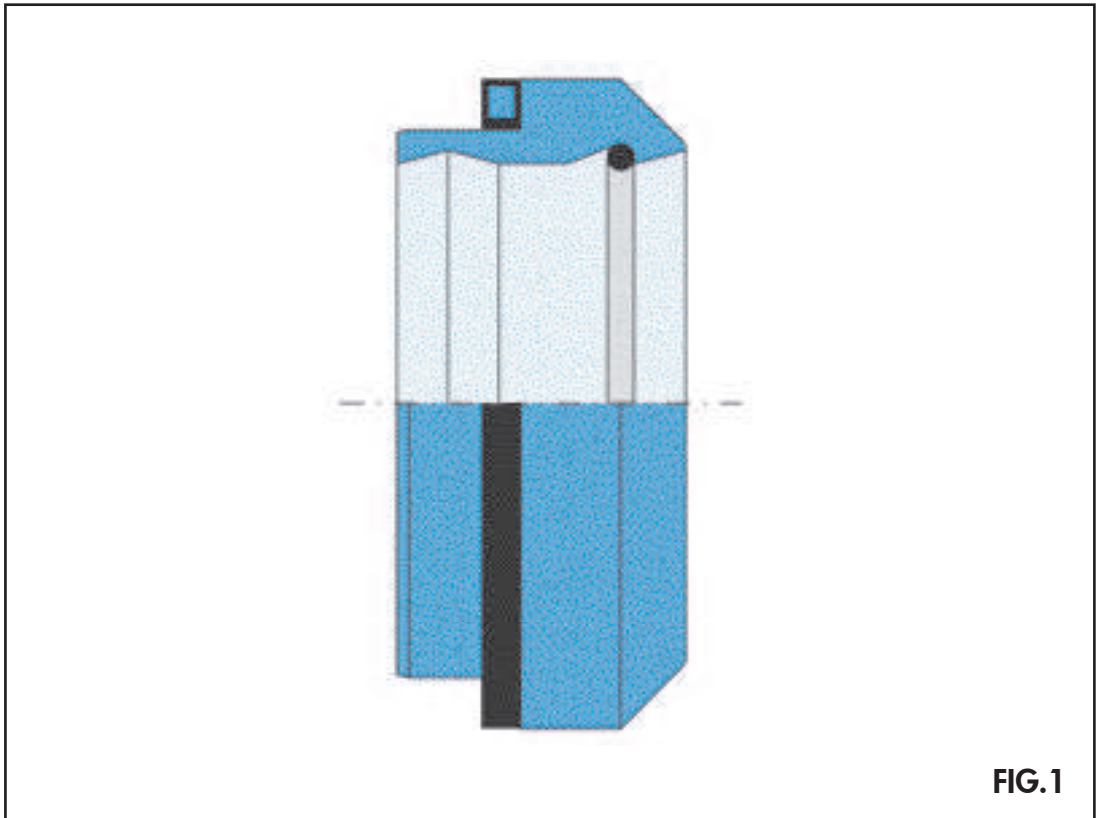

FIG.1

a) **EASY ASSEMBLY**

b) **ABSOLUTELY TIGHT SEALING**

c) **AUTOMATIC CLOSING**

d) **INTERCHANGEABILITY ON ALL FITTINGS WITH CUTTING RING 24° DIN 2353 (ISO 8434-1)**

1.2 GUARANTEE OF EXPERIMENTATION, TESTS, TRIALS

The clamping ring AR3/C (Figure 1) was conceived, designed and tested on the basis of check and control methods applied in the development of new products according to a FLOW CHART defined in the ISO 9001 CERTIFICATION, that RASTELLI RACCORDI has implemented in its company structure.

1.3 PRODUCT TRACEABILITY SCHEME

The rings AR3/C are preventively marked to allow the product traceability following the scheme of the Figure 2 below.

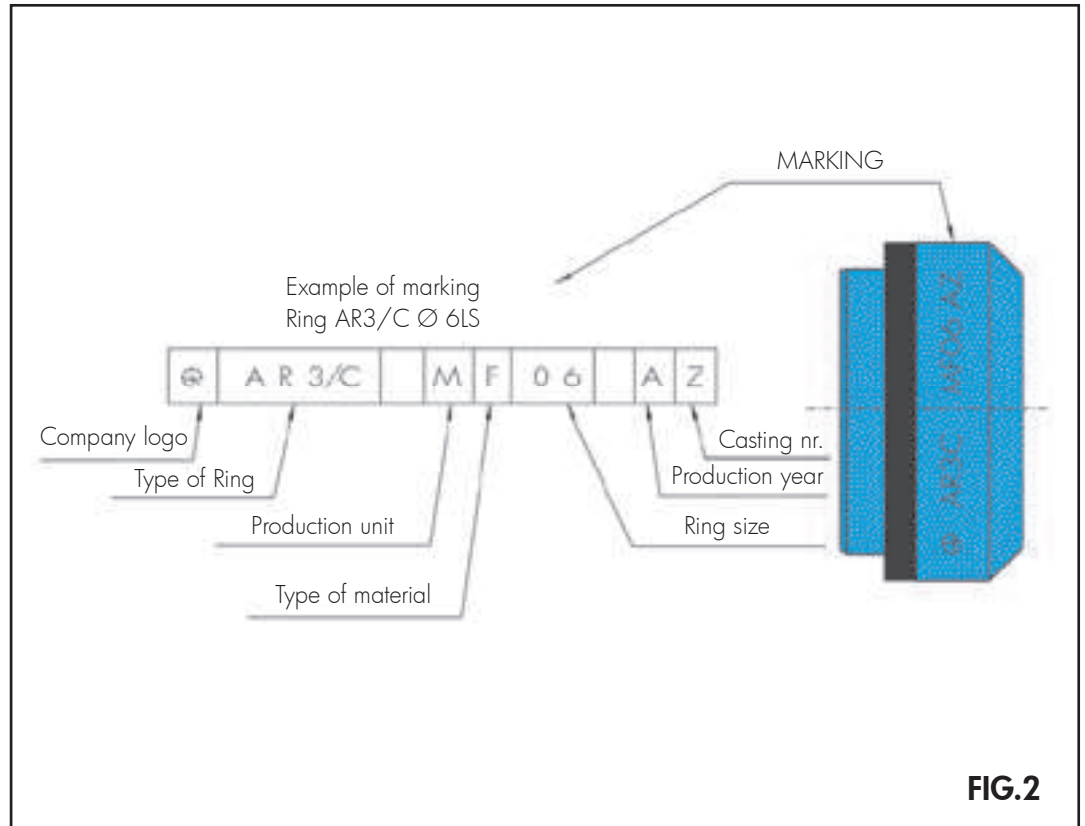

2. CHARACTERISTICS

2.1 EASY ASSEMBLY

The new clamping ring AR3/C allows the operator to perform assembly without the usual time-consuming and painstaking operations related to the control of the ring cut on the tube, such as:

- 1) Putting identification marks on tube and nut to check the number of nut turns and have the assurance of a correct clamping.
- 2) Using dynamometric spanners to check the torque (Nm) required for a specific clamping.

2.2 ABSOLUTELY TIGHT SEALING

The ring AR3/C at its axial end, at the head side, features a vulcanised rubber sealed washer (Figure 3) and at rear an O-ring gasket placed in an annular recess.

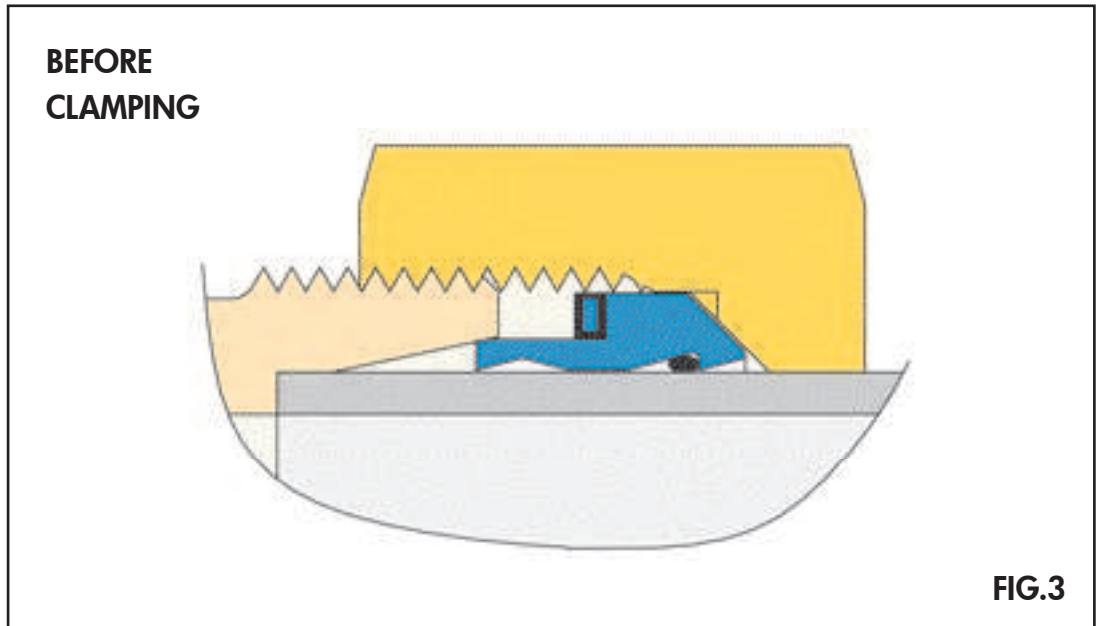

In the clamping phase, the ring AR3/C, pushed by the nut onto the 24° cone of the fitting, causes the compression of the rubber seal of the washer on the fitting, which takes the position indicated in Figure 4, making the system absolutely tight.

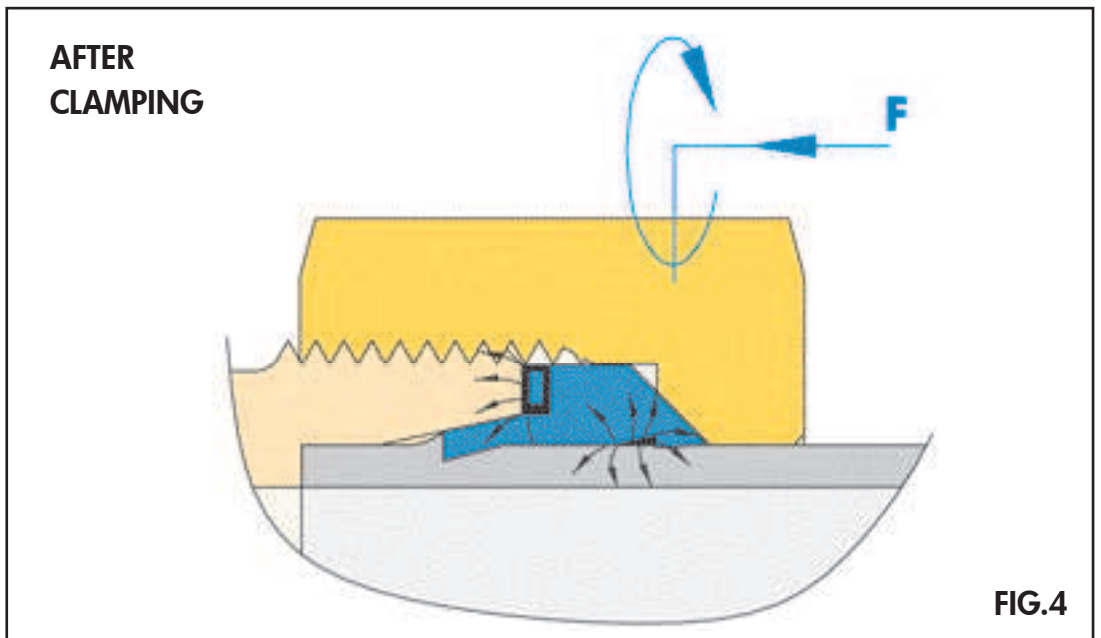

The special form of the o-ring seat is also crucial, which due to the spring effect of the ring, pre-compressed by torque **F** during clamping and thanks to the cutting shape of its rear and encloses the tube around its whole circumference (Figure 4), guaranteeing perfect tightness.

2.3 AUTOMATIC CLOSING LIMIT also said: AUTOMATIC CLOSING

The automatic closing of the ring AR3/C on the fitting body occurs when the ring itself, as an effect of the nut tightening, slides on the 24° cone of the fitting body (Figure 5) until the 2 surfaces A and B come in contact forming one piece, so forcing the operator to stop the clamping.

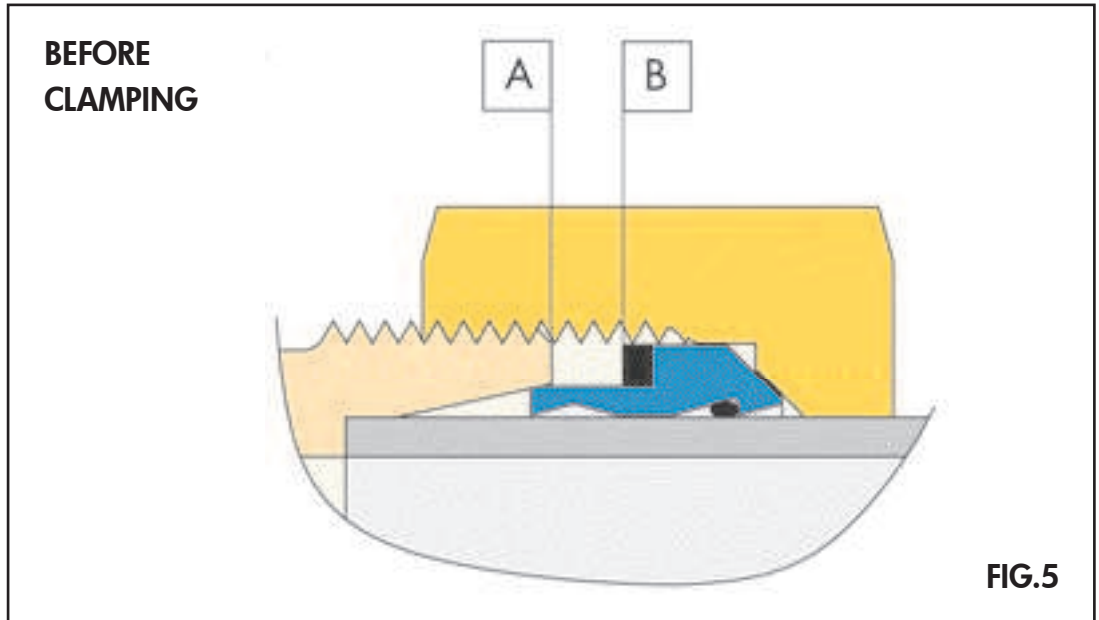

This system ensures the best cutting of the ring AR3/C into the tube. The only recommendation to follow is to check, after loosening the nut, that surfaces A and B are perfectly in contact on their whole circumference (Figure 6)

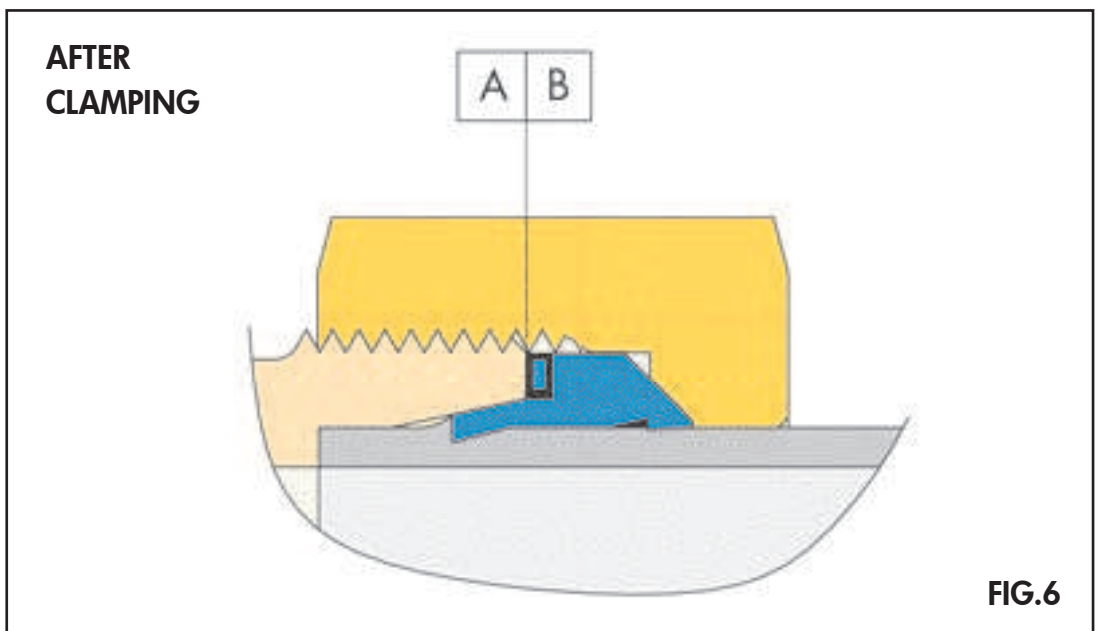

In the last clamping phase (Figure 6) the vulcanized washer has also the purpose to adjust possible off-centering caused by the addition of tolerances of the different components (BODY, TUBE, RING, NUT) compressing itself until, together with the fitting body and ring AR3/C, it becomes one complete piece.

2.4 INTERCHANGEABILITY ON ALL FITTINGS WITH CUTTING RING 24° DIN 2353 (ISO 8434-1)

The new ring AR3/C is perfectly interchangeable with all the other clamping rings with one or two cutting edges which are used on the 24° cone fittings DIN 2353 (ISO 8434-1)

With the ring AR3/C it is possible to use all equipments for manual pre-assembly (hardened steel blocks type TN 195) that are normally used for the traditional clamping rings RASTELLI TN 88 - TD 88 - AR3.

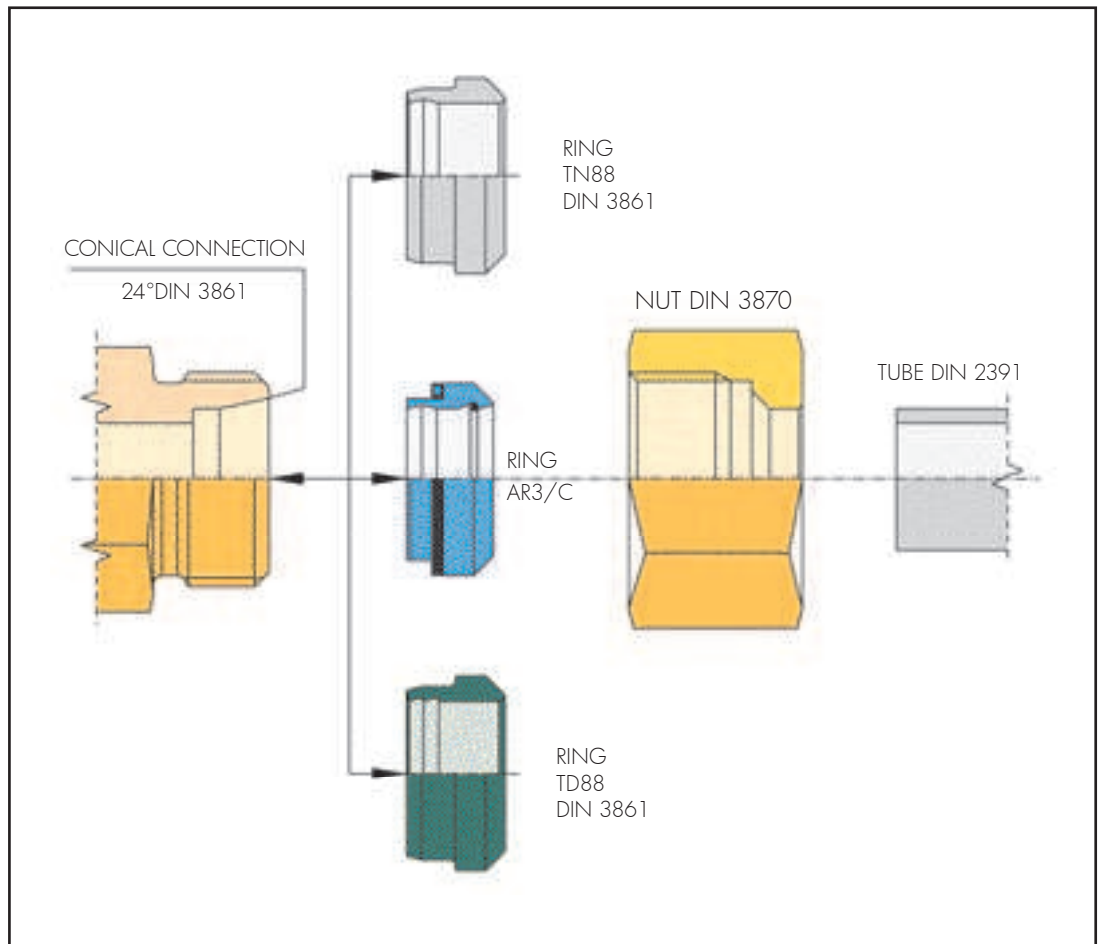

ORDER PROCEDURE: To order fittings AR3/C just replace code TN with code TC.

Example: **TN92GG-10LR** (Ring TN88, 1 cutting edge – stainless steel and series LL)

TD92GG-10LR (Ring TD88, 2 cutting edges)

TA92GG-10LR (Ring AR3 – Only stainless steel)

TC92GG-10LR (Ring AR3/C – Only carbon steel)

For its special characteristic of ABSOLUTE TIGHTNESS, the ring AR3/C is recommended for a use with all fittings with seals NBR (iron) or FPM (stainless steel) "SOFT SEALS", as they guarantee the same results as ring AR3/C, like absence of leakage, no oozing and externally dry tubes.

In particular, it is recommended to use fittings of the **Series TN 400** (TN 419-420-421-426-432), which replace TN 119-120-121-126-132 .

AR3/C

CUTTING RING
WITH TIGHT SEALING
FOR PIPE FITTINGS
DIN 2353 (ISO 8434-1)

3 TECHNICAL DATA

3.1 TECHNICAL DATA

SURFACE FINISH

WHITE PASSIVATION treatment Fe/Zn 8 – UNI ISO 2081 with trivalent Chrome (free from hexavalent chrome) with SEALER in compliance with the European Norm EC 200/53

MATERIALS AND MAX. WORKING TEMPERATURES „TB“ (DIN 2401)

Metal parts: Steel (DIN 3859) -40°C ÷ +120°C

Rubber parts: NBR (Perbunan® Bayer) -35°C ÷ +100°C

PRESSURES

The PN RATED pressure corresponds to a safety factor of PN x 4.

The pressures indicated are the MAXIMUM WORKING pressures, including peak values under NORMAL working conditions and with MAXIMUM WORKING temperatures ALLOWED TB (DIN 2401).

For the rings AR3/C with seals observe the guidelines of norm DIN 7716 “RUBBER PRODUCTS” concerning storage, cleaning, and maintenance.

AR3/C TIGHT CLAMPING RING



SERIES	Ø TUBE	PN	Ø G	M	ORDER CODE	WEIGHT KG. X 100PCS
L	6	315	6	9	AR3/C - 6 LS	0,21
	8		8	9	AR3/C - 8 LS	0,26
	10		10	9,3	AR3/C - 10 LS	0,31
	12		12	9,5	AR3/C - 12 LS	0,36
	15		15	9,5	AR3/C - 15 L	0,66
	18		18	9,5	AR3/C - 18 L	1,05
	22	160	22	11,5	AR3/C - 22 L	1,05
	28		28	11,5	AR3/C - 28 L	1,33
	35		35	13	AR3/C - 35 L	3,08
	42		42	13	AR3/C - 42 L	3,74
S	6	630	6	9	AR3/C - 6 LS	0,21
	8		8	9	AR3/C - 8 LS	0,26
	10		10	9,3	AR3/C - 10 LS	0,31
	12		12	9,5	AR3/C - 12 LS	0,36
	14		14	10	AR3/C - 14 S	0,73
	16	400	16	10	AR3/C - 16 S	0,87
	20		20	13	AR3/C - 20 S	1,80
	25		25	13,3	AR3/C - 25 S	2,52
	30		30	14	AR3/C - 30 S	3,60
	38		315	38	14	AR3/C - 38 S

4 ASSEMBLY

4.1 ASSEMBLY INSTRUCTIONS

a). PREPARATION OF INSIDE AND OUTSIDE OF THE TUBE

- a.1) Cut the tube at right angle. A maximum deviation of 0.5° is allowed from the tube axis.
- a.2) The right angle-cutting is easier by using a hand saw with suitable device. **ATTENTION!:** Do not use PIPE CUTTERS OR CUTTING-OFF MACHINES.
- a.3) Slightly trim the tube internally and externally without damaging the mating surface (max chamfering $0,2 \times 45^\circ$).

b). MINIMUM TUBE LENGTH

- b.1) Minimum length of the straight tube in elbows: at least twice the height of the nut TN81 (H). (Figure 1)
- b.2) Minimum length of the tube between two fittings: $2,5 \div 3$ times the height of nut TN81 (H). (Figure 2)

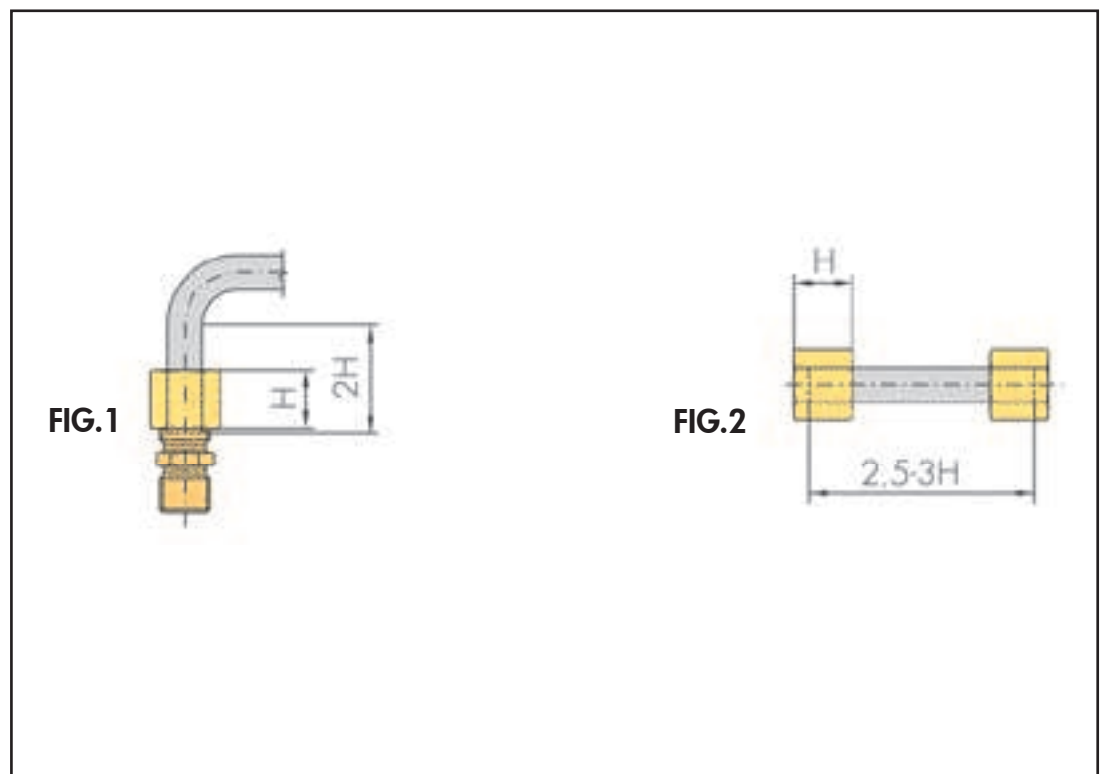

c). PREPARATION OF THE FITTING (LUBRICATION)

- c.1) Oil the ring AR3/C, the thread of TN 81, the conical seat and the thread of the fitting of the pre-assembly tool TN 195.
- c.2) Insert nut TN 81 and ring AR3/C until the end of the tube with the ring head towards the thread of nut TN 81.

4.2 DIRECT CONNECTION TO THE FITTING BODY FOR STEEL

- d.1) Insert the tube into the fitting until it stops and tighten nut TN 81 completely by hand
ATTENTION!: The tube should rest completely against the fitting shoulder, otherwise an accurate cut of ring AR3/C is not possible.
- d.2) Tighten nut TN 81 till meeting a strong (sudden) resistance caused by the coupling of surfaces A – B (AUTOMATIC CLOSING) (Figure 3) . Control that the tube is not turning with nut TN 81 .

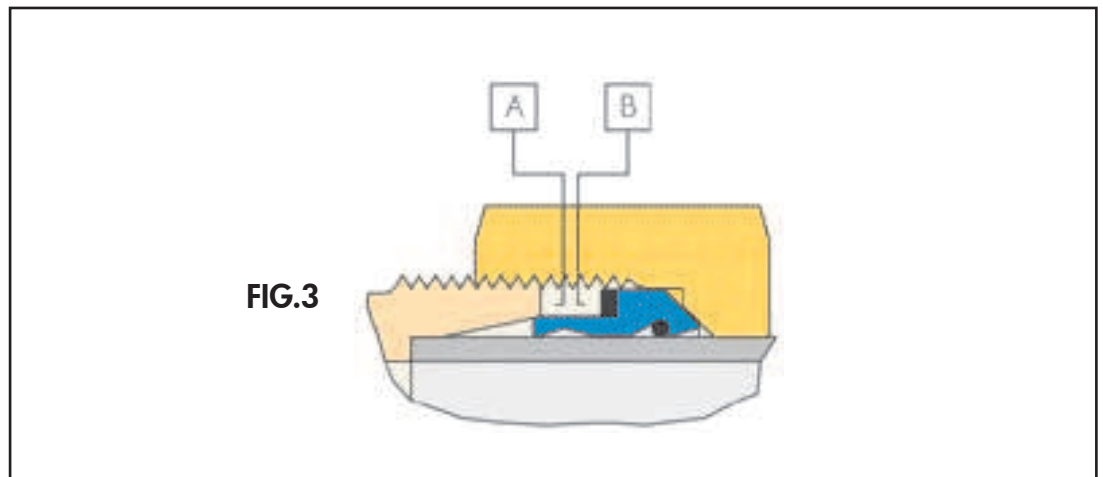

e). CONTROL

- e.1) Loosen nut Tn 81 and check that surfaces A – B are in contact on their whole circumference. (Figure 4).
ATTENTION!: The disassembled tube ends should be reassembled on the same fittings used for the clamping.

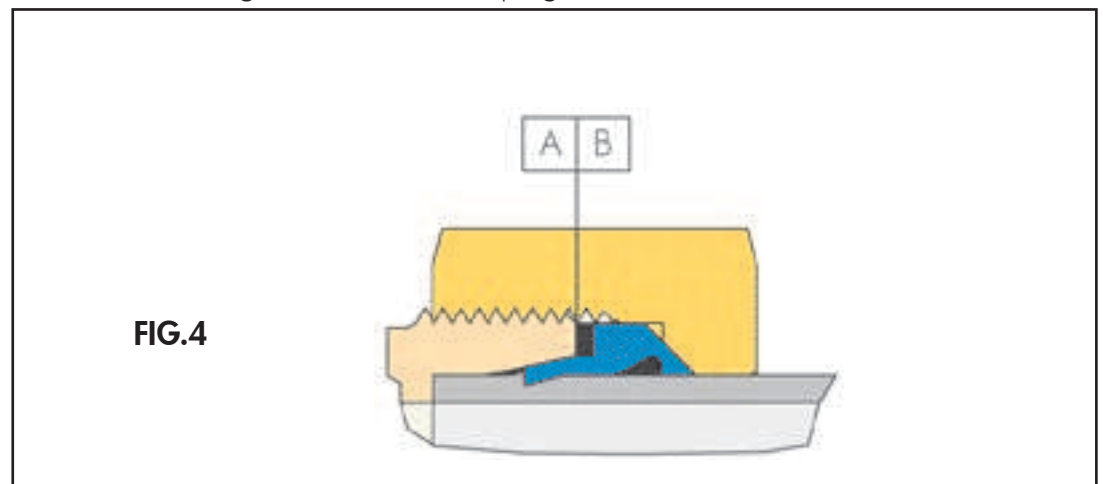

f). REASSEMBLY

- f.1) After a tube connection has been dismantled, nut TN 81 must be tightened again using a NORMAL SPANNER on the fitting like during the first assembly (with the same torque) and supporting the fitting with a second spanner.

4.3 ASSEMBLY WITH THE PRE-ASSEMBLY TOOL TN 195

g). CHECKING THE PRE-ASSEMBLY TOOL TN 195

- g.1) The conical seat of pre-assembly tool TN 195 is subject to wear and therefore it should be regularly checked (after the 50th assembly operation) using the special gauge TN 196 to verify its taper. When connecting tubes with large diameters (over 20S), the fitting **MUST** definitely be pre-connected in the special tool TN 195.

h). PRE-ASSEMBLY

- h.1) Insert the tube into tool TN 195 till it stops and tighten nut TN 81 completely by hand.
ATTENTION!: The tube should rest completely against the tool shoulder, otherwise an accurate cut of ring AR3/C is not possible.
- h.2) Tighten nut TN 81 till meeting a strong (sudden) resistance caused by the coupling of surfaces A – B (AUTOMATIC CLOSING). (Figure 5). Control that the tube is not turning with nut TN 81.

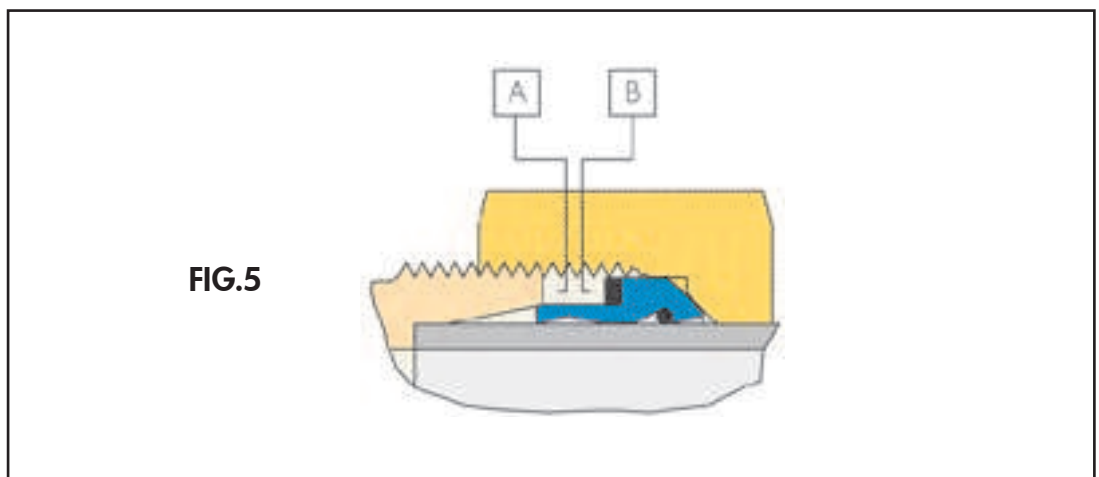

i). CONTROL

- i.1) After a pre-assembly, loosen nut TN 81 from tool TN 195 and check that surfaces A – B are in contact on their whole circumference. (Figure 6)

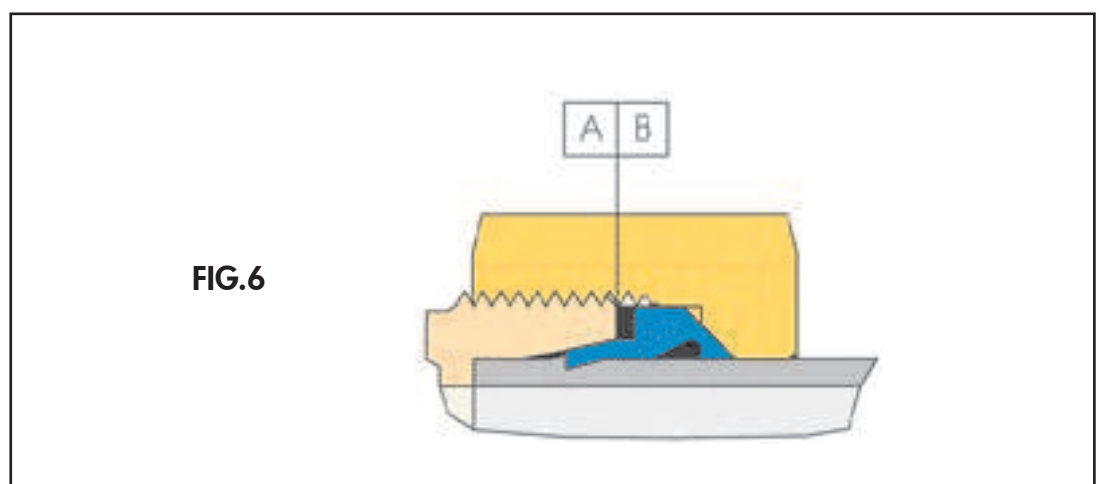

j). FINAL ASSEMBLY

- j.1) Manually turn nut TN 81 (pre-assembled) on the fitting body till meeting the point of resistance. Then tighten with NORMAL SPANNER applying the same torque as in the pre-assembly and supporting the fitting with a second spanner.

k). REASSEMBLY

- k.1) After a tube connection has been dismantled, nut TN 81 must be tightened again on the fitting using a NORMAL SPANNER like during the first assembly (with the same torque) and supporting the fitting with a second spanner.

4.4 ASSEMBLY WITH PNEUMATIC MACHINE TN 294A

l). CONTROL OF CONICAL FORM TN 287A

- l.1) The conical seat of form TN 287A is subject to wear and therefore it should be checked before the pre-clamping operation using the special gauge TN 196 to verify its taper.

m). PRE-ASSEMBLY

- m.1) The pressure of the machine shall be set according to the table below.

SIZE	PRESSURE BAR	SIZE	PRESSURE BAR	SIZE	PRESSURE BAR	SIZE	PRESSURE BAR	SIZE	PRESSURE BAR	SIZE	PRESSURE BAR
6LS	0.7	12LS	1	22L	1.7	42L	4.5	20S	3.2	38S	4.5
8LS	0.8	15L	1.1	28L	2.4	14S	1.6	25S	3.4	-	-
10LS	0.8	18L	1.3	35L	2.6	16S	1.9	30S	3.7	-	-

- m.2) Put plate TN 286A (1) and conical form TN 287A (2) in the machine (Figure 7).
- m.3) Place tube with ring AR3/C and nut TN 81 between plate and conical form (Figure 8).

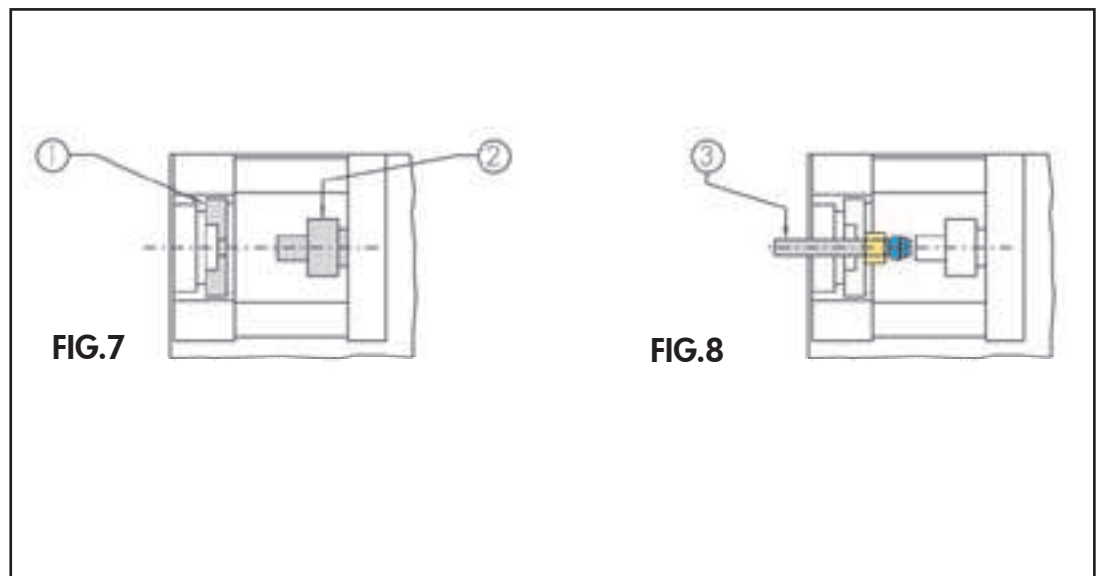

AR3/C

**CUTTING RING
WITH TIGHT SEALING
FOR PIPE FITTINGS
DIN 2353 (ISO 8434-1)**

- m.4) Insert the tube into conical form TN 287A until it stops.
ATTENTION! : The tube should rest completely against the conical piece shoulder, otherwise an accurate cut of ring AR3/C is not possible.
- m.5) Firmly holding the tube, start the machine by pressing the safety door.

n). FINAL ASSEMBLY

- n.1) Introduce the end of the pre-assembled tube into the fitting body and manually turn nut TN81 till meeting the point of resistance, then tighten with a NORMAL SPANNER till meeting a strong (sudden) resistance.

5. NORMS

5.1 IMPORTANT GUIDELINES

- a) The tubes with a small diameter can be directly clamped in the fittings assembled on the plant.
- b) For easier tightening, the length of the spanner can be extended until 1.5 times the width of the hexagon.
- c) After completing the pre-assembly, nuts TN 81 shall be tightened with a NORMAL SPANNER.
- d) When assembling the plant, if the tubes are proportionally very long or particularly subject to stress, they have to be supported and fixed by means of collars. RASTELLI produces and supplies these collars in a complete range of sizes and in different materials (polypropylene, ultramide and aluminium).
- e) Special attention must be paid to the vibrations of high pressure rubber pipes, if the user connects them, at his own risk, with the fittings DIN 2353, which are notoriously suitable for steel pipes only.

6. LIABILITY

6.1 CIVIL LIABILITY FOR PRODUCTS

Our company is insured, for an ultimate figure, by a Policy of Civil Liability for Products, which also covers accidents. The law (D.P.R. 224/88 EG/85-374), however states that "liability" will be attributed to the party which proves to have been negligent. The product is liable if the damage caused proves to be due to a defect in the product itself.

The retailer, in turn, is responsible for ascertaining whether his customer is fully aware of how the product should be used.

The user is liable if, despite being in possession of instructions relating to use of the product, he fails to follow these instructions, believing them to be merely a superfluous formality.

The law, therefore, prescribes that both parties should accept their due measure of responsibility, as it is better that everyone should make a concerted effort to avoid cases or accidents of this nature.

The guarantee rights can be claimed by the user only if all the instructions contained in the RASTELLI Catalogues have been observed. A failure to observe them may impair the functional safety of the product and implicate the loss of the guarantee rights.

We reserve the right to ownership of this catalogue in accordance with the law, reproduction and/or copies are strictly prohibited without our prior authorization.

The figures and weights set out in the tables in this catalogue are only intended as approximations. RASTELLI RACCORDI reserves the right to make any technical or dimensional variations to its products, or change their appearance, in any way they deem fit.

DESIGN:

Technical and Advertising Service of
RASTELLI RACCORDI S.r.l.